

Photoelectric distributed energy supply for Maglev propulsion system

S. Plaxin & Yu. Shkil'

Institute of Transport Systems and Technologies "Transmag" of the Ukrainian National Academy of Sciences, Pisargevskogo str., 5, Dnepropetrovsk, UKRAINE

ABSTRACT: The construction of the energy supply system for Maglev linear synchronous driver on the base of photovoltaic modules network is conceptually considered.

1 INTRODUCTION

In this work it's conceptually considered the construction of the energy supply system for linear synchronous driver (LSD) of the Maglev guideway from the distributed network of photo-voltaic transformers.

The power and energy characteristics of linear synchronous drivers depend on the means of currents in the driver coils, the gap between the way coil and excitation coil Z , pole division τ , the coil sizes, the Maglev super-conductive magnets number, the fed section length and other structural parameters.

The conducted calculate analyze (Novikov 2004) of base construction of driver shows that driver power efficiency increases with decrease of section's length. The dependence of the LSD characteristics on the section length of the way coil is shown on Figure 1.

At reduction of section length up to the Maglev sizes the main role plays the decrease of inductive resistance and, in less degree, of active one. The decrease of means of these resistances allows to diminish the voltage of supply source and the same to minimize the requirements to the commutation elements. At further reduction of section length the voltage of supply diminishes sharply due to reduction of anti-emf, that is related to reduction of amount of sources of the excitation field interactive with the guideway section. For such linear driver construction the limit section length is the length of the way coil $2\pi/3$. Before the sections of such length

were not even examined due to the high cost of semiconductor transformers.

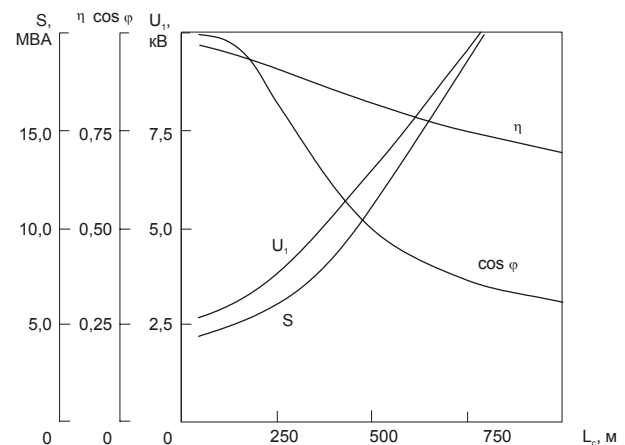

Figure 1: The dependence of the LSD characteristics on the section length of the way coil.

As far as development of semiconductor technique a price factor left off to restrain reduction of section length and obvious advantages of linear driver with sections sizes comparable with the sizes of the way coils, presently can be realized the most completely at the conditions of autonomous control and electric power providing of every way coil.

2 PHOTOELECTRIC DISTRIBUTED ENERGY SUPPLY

Open Such task can be settled, if as a source of electric power to use the solar-energy distributed system with the proper way coil control system. Estimated calculations (Mhitaryan 2002) show that from 1

square m of photo-voltaic panel during a year it is possible to obtain on average 123 kW·h of electric power depending on the environmental conditions of East Europe and technical characteristics of the photo-voltaic panel. From other side, the results of researches of Maglev characteristics (Bocharov 1988) testify to that specific energy necessary for Maglev propulsion does not exceed $1.23 \cdot 10^{-4}$ W·h/kg·m for the driving segment 100...300 km. It means that the energy produced during one year by 1 square m of photo-voltaic panel is sufficient for propulsion of approximately 1000,000 tons weight on the distance of 1 m. The use of solar energy for Maglev supply substantially changes configuration of the guideway of the high-speed ground vehicle (HSGV) and in the first turn the navigation and movement control subsystems. For comparison on Figures 2, 3 the structural charts of the HSGV energy supply from centralized network and from autonomous solar panels consequently are represented. The traditional construction includes the system of external energy supply, carrying substation, transformer with the powerful regulators of frequency and current, power feeders (phase A, phase B, phase C), power switches B1, B2...BN and power sections of the way coils and movement control subsystem. As visible, at movement of vehicle the system in whole works with enormous powers, passed on large distances to the long sections. All now operating HSGV lines have approximately such structure.

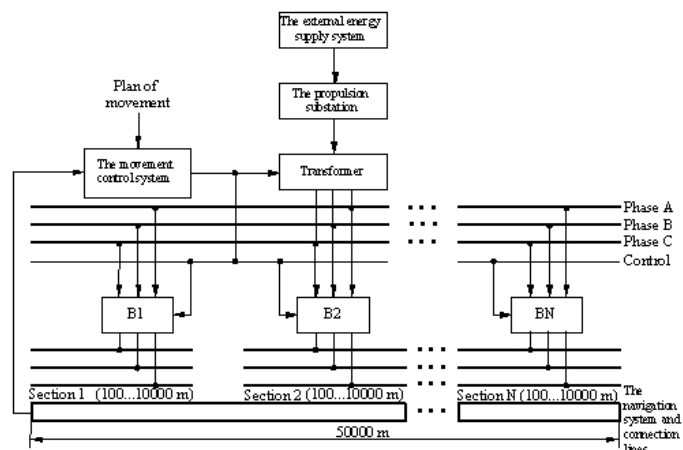

Figure 2: Structure of LSD energy supply from the external energy source. Power circuits are selected by bold lines

Unlike the considered structural chart, the system of HSGV energy supply from solar panels is the distributed system (Fig. 3). The solar way power station (SWPS) consisting of solar panel (P), store (S) and inverter loaded by the way coil (section 1), and also the movement control subsystem, the subsystem of navigation and control are the main elements of the system. The quantity of SWPS must be equal to the quantity of way coils on driving segment. So the solar-energy distributed system is the set of large

quantity of same type photo-voltaic energy stations of small productivity, each of which works on single way coil, and each coil switches on only at the moment of passing above it a superconductive magnet of Maglev-train.

At such structure of energy supply a necessity in the transmission of large energy volumes on large distances is eliminated, more high degree of reliability of functioning of the system on the whole is provided. The single power element is inverter connected with a store and way coil.

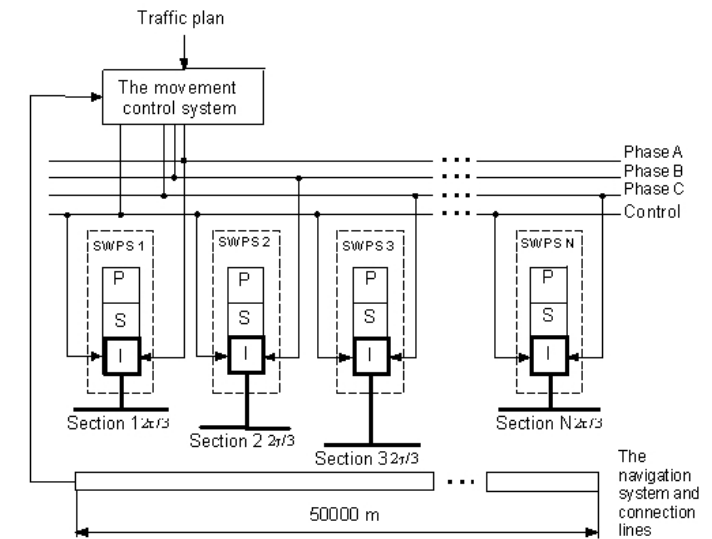

Figure 3: The structural chart of the LSD energy supply from solar panels. Power circuits are selected by bold lines

The principle feature of production of solar electricity is its uneven production during a day and a year. Independence of the energy supply system from these vibrations is provided by introduction in the complement of the SWPS the store of electric energy, carrying out accumulation of electric power in the period of surplus of solar radiation (day, summer period) and its expense in the period of scarcity (night, winter months).

The time of passing by Maglev train a distance of 1 m at movement in the levitative mode with nominal speed may be 7-70 ms. Consequently, inverter must work in the mode of short-time power output, and this condition produces the certain requirements to the energy store at planning of the SWPS control system. At first, it must work in the cyclic charge-discharge mode so that to a next discharge the accumulated specific energy would be no less than it is needed for propulsion of vehicle. Secondly, during light day-time it must accumulate enough energy for working in a night-time. Thirdly, it must keep a reserve energy for working during a few days at poor

weather conditions (fog, cloudiness). Fourthly, it must possess ability to accumulate in daylight summer time so much energy (surplus for this time of year), that in winter time to give it gradually in load, what is the guarantee of the independent transport way energy supply during whole year. In addition, a store must possess ability of fast discharge and fast recharge, and for prolongation of service term to have small attitude of discharge energy to a nominal capacity.

To similar requirements can satisfy, for example, a store consisting of accumulator, ionistor, electrolyzer, capacity for storage of hydrogen and fuel element. An accumulator is able to provide the energy for the SWPS work during period from one to a few days, ionistor – to provide a fast own charge and, that is especially important, fast own discharge (its specific energy of discharge is enormous). That is the guarantee of protecting an accumulator from large overcharge and discharge currents. The other three elements of store are intended for providing of energy system work under load over whole year. The SWPS block diagram is shown on the Figure 4.

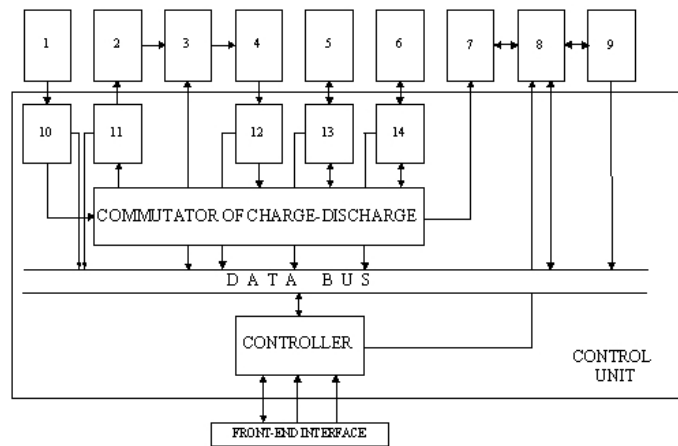

Figure 4: The SWPS block diagram: 1 – solar panel; 2 – electrolytic tank; 3 – hydrogen storage; 4 – fuel element; 5, 6 – accumulative batteries; 7 – ionistor; 8 – inverter; 9 – guide-coil; 10 – input electrical energy counter; 11 – charge counter; 12 – consumption counter; 13, 14 – charge-discharge counter

For providing of day's consumption of energy by single SWPS is required store by a capacity of 200...250 W·h without taking into account losses in the transformer. For providing of annual consumption it's necessary to have a store by a capacity of approximately 60...70 thousand W·h. Inverter in SPEU works in the pulse mode and by preliminary estimates must to provide in a coil pulse power approximately of 30 kW.

3 THE LSD CONTROL SYSTEM AT THE SOLAR SOURCE OF ENERGY SUPPLY

The system must include a few subsystems: the navigation subsystem, subsystem of bi-directional communication for vehicle control and diagnostics, the SWPS control and diagnostics subsystem. In our control system the principle of measuring of phase changes for the movement control and information transfer is used (Figure 5).

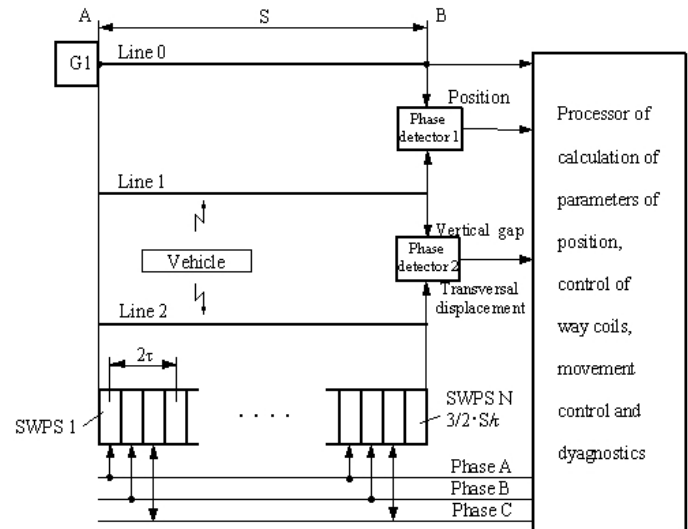

Figure 5: The LSD Maglev control system counter.

3.1 The navigation subsystem

The initial (A) and the end (B) points of driving segment are connected by the concerted line of transmission of the microwave signal. In a point A the generator G1 (e.g. 300, 006 kHz, with stability 10^{-10}), synchronized with all other generators, is set, in a point B – a few phase detectors are set. In a line the mode of standing waves with strong fixed initial phase to the point A is set. The frequency of a signal emitted from a vehicle into a line is equal to generator G1 frequency. In a phase detector it is selected a signal the phase of which changes in relation to the phase of the generator G1 signal with speed, equal the Maglev train speed.

The change of phases between these signals is proportional to the long of way, passed by Maglev train from a point A in the direction of point B. Non identity of counting of phase is eliminated by the proper choice of frequencies of mobile and immobile generators.

The navigation system also provides determination of position of Maglev vehicle in relation to a guideway – vertical gap and transversal displacement. For this purpose the signal of the same frequency comes from Maglev vehicle on a phase detector in a point B on two lines – line 1 and the line

2. The change of phases of these signals is the function of lateral displacement and vertical gap of Maglev vehicle.

3.2 *The control subsystem of the solar way power stations*

The guideway is built so that on one way coil would be one SWPS. It is approximately 1 unit on 1 m of way. Each SWPS is connected to one of fiders A, B, C. This fiders – not power, only signal (synchrony signal). This synchrony signal is present simultaneously on all SWPS of driving segment and its frequency (0-50 Hz) determines speed of Maglev propulsion. The SWPS connection to the “own” way coil is realized in that moment when Maglev vehicle is above this coil. The signal about Maglev vehicle position got in a point B is an informative signal for the switch on of the relevant coil.

3.3 *The SWPS control and diagnostics subsystem*

This subsystem provides the control of the state of accumulator battery, inverter, controller and diagnostics of the SWPS by method of before-start-control of the driving segment in whole by the forced testing in the real time.

The weaknesses and limitations of conception are obvious: on driving segment there can not be more than one vehicle, the lines of transmission of the microwaves signals must have large quantity of amplifiers which compensate the losses: the solar panels will be exposed to the considerable aerodynamic loadings.

4 CONCLUSION

The short analysis of the balance of power necessities of Maglev train and possibilities of the photo-voltaic energy supply system allows to do a resume about possibility of application of the distributed photo-voltaic system as a system of the HSGV energy supply. So, in the conditions of really attainable annual material well-being by solar energy in East Europe the electric energy, produced by 1 square m of solar panel located along the guideway is enough that during a year to provide the hourly passing of three magnetoplans weighing 40 tons each with an interval 20 minutes.

The complied element of the way power plant, consisting of solar panel, store and inverter with load as the way coil, is offered. The transport system created by connection of such same type elements of

low-energy-capacity and compatible in electromagnetic sense possesses the more high degree of functioning reliability and, consequently, the more high degree of safety.

In the offered Maglev control system with the distributed energy supply system the principle of measuring of phase changes between a supporting signal and signal from mobile Maglev vehicle is used for the movement control and information transfer.

Bocharov, V.I., Sally, I.V. & Dzenzerskiy, V.A. 1988, *Transport on superconductive magnets*, Rostov University.

Mhitaryan, N.M. 2002, *Solar power Driverering. Systems, technologies, applications*. Kiev: Naukova dumka.

Novikov, V.F., Plaksin, S.V. & Shki, I Yu.V. 2004, Photoelectric distributed system of magnetoplan energy supply, *Problems and trends of transport systems development; The reports of II science-practical conference. 2004*, Kiev: 65-66.